



e-mail: serwis@techsterownik.pl

phone: +48 33 875 93 80

ul. Skotnica 120, 32-652 Bulowice

Service:

ul. Biała Droga 31, 34-122 Wieprz

Central headquarters:

EN

EU-C-2N
USER'S MANUAL

TECH
CONTROLLERS

TECH
CONTROLLERS

WARRANTY CARD

TECH company ensures to the Buyer proper operation of the device for the period of 24 months from the date of sale. The Guarantor undertakes to repair the device free of charge if the defects occurred through the manufacturer's fault. The device should be delivered to its manufacturer. Principles of conduct in the case of a complaint are determined by the Act on specific terms and conditions of consumer sale and amendments of the Civil Code (Journal of Laws of 5 September 2002).

CAUTION! THE TEMPERATURE SENSOR CANNOT BE IMMERSSED IN ANY LIQUID (OIL ETC). THIS MAY RESULT IN DAMAGING THE CONTROLLER AND LOSS OF WARRANTY! THE ACCEPTABLE RELATIVE HUMIDITY OF THE CONTROLLER'S ENVIRONMENT IS 5÷85% REL.H. WITHOUT THE STEAM CONDENSATION EFFECT. THE DEVICE IS NOT INTENDED TO BE OPERATED BY CHILDREN.

Activities related to setting and regulation of the controller parameters described in the Instruction Manual and parts wearing out during normal operation, such as fuses, are not covered by warranty repairs. The warranty does not cover damages arising as a result of improper operation through the user's fault, mechanical damage or damage created as a result of fire, flood, atmospheric discharges, overvoltage or short-circuit. The interference of an unauthorized service, wilful repairs, modifications and construction changes cause the loss of Warranty. TECH controllers have protective seals. Removing a seal results in the loss of Warranty.

The costs of unjustifiable service call to a defect will be borne exclusively by the buyer. The unjustifiable service call is defined as a call to remove damages not resulting from the Guarantor's fault as well as a call considered unjustifiable by the service after diagnosing the device (e.g. damage of the equipment through the fault of the client or not subject to Warranty), or if the device defect occurred for reasons lying beyond the device.

In order to execute the rights arising from this Warranty, the user is obliged, at his own cost and risk, deliver the device to the Guarantor along with a correctly filled-in warranty card (containing in particular the sale date, the seller's signature and a description of the defect) and sales proof (receipt, VAT invoice, etc.). The Warranty Card is the only basis for repair free of charge. The complaint repair time is 14 days.

When the Warranty Card is lost or damaged, the manufacturer does not issue a duplicate.

.....
seller's stamp

.....
date of sale

Safety

Before using the device for the first time the user should read the following regulations carefully. Not obeying the instructions included in this manual may lead to personal injuries or controller damage. The user's manual should be stored in a safe place for further reference. In order to avoid accidents and errors it should be ensured that every person using the device has familiarized themselves with the principle of operation as well as security functions of the controller. If the device is to be sold or put in a different place, make sure that the user's manual is there with the device so that any potential user has access to essential information about the device. The manufacturer does not accept responsibility for any injuries or damage resulting from negligence; therefore, users are obliged to take the necessary safety measures listed in this manual to protect their lives and property.

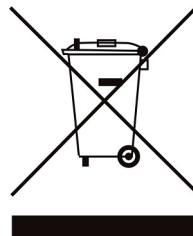

We are committed to protecting the environment. Manufacturing electronic devices imposes an obligation of providing for environmentally safe disposal of used electronic components and devices. Hence, we have been entered into a register kept by the Inspection For Environmental Protection. The crossed-out bin symbol on a product means that the product may not be disposed of to household waste containers. Recycling of wastes helps to protect the environment. The user is obliged to transfer their used equipment to a collection point where all electric and electronic components will be recycled.

Description

EU-C-2N sensor is intended to be installed on the windows of particular heating zones. When the window is opened, the sensor sends the information to the main controller which deactivates heating in the zone after a pre-set delay time.

Technical data

Power supply.....batterie ER14250
 Operation temperature.....5-50°C
 Operation frequency.....868 MHz
 Ambient humidity.....5-85%

Installation

In order to install EU-C-2 sensor, place double-sided tape on the upper part of the window frame (not where the hinges are located) and stick the back of the sensor to the tape. Next, put the front part of the sensor in its place. The installation method is illustrated in the picture below.



NOTE

The magnet should be placed on the window casement!
 Maximum distance between the sensor and magnet up to 15 mm.

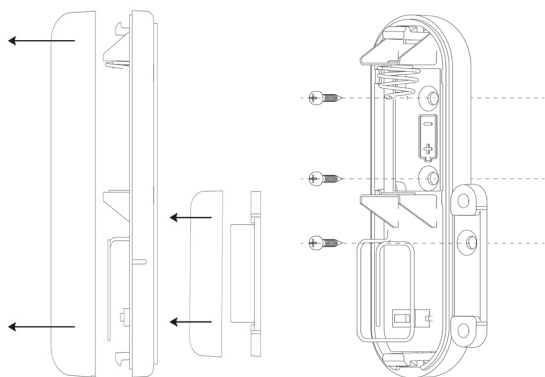

Sensor registration

Once 'Registration' function in the main controller has been activated, press quickly the communication button on a given EU-C-2N sensor.

If the registration attempt has been successful, the main controller will display an appropriate message and the control light on EU-C-2N sensor will flash twice.

If the control light goes on permanently, there is no communication with the main controller.

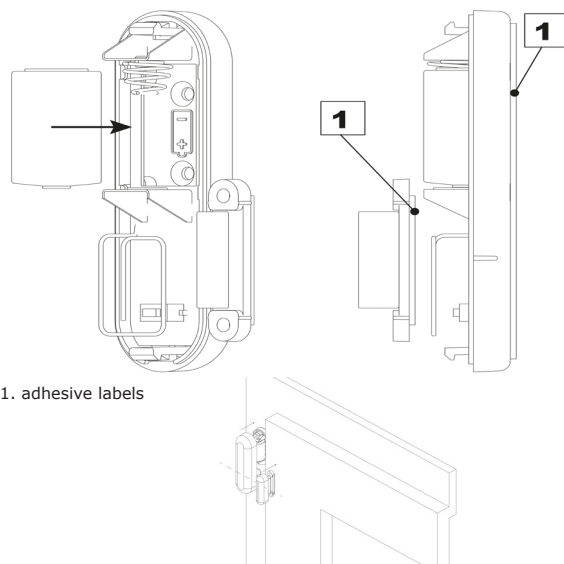
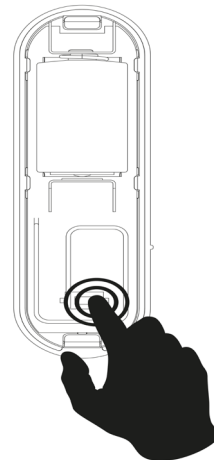

1. adhesive labels

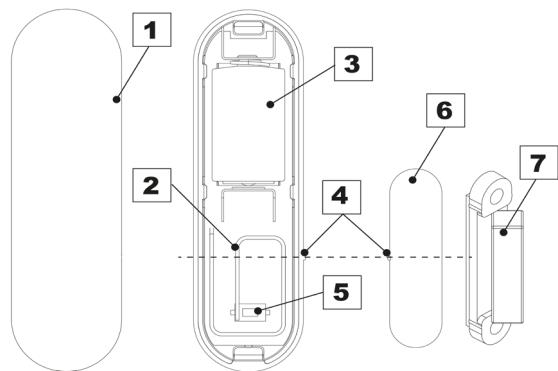

1. casing
2. antenna
3. battery
4. montage axle, position of the sensor relative to the magnet
5. registration button
6. casing
7. magnet

EU Declaration of Conformity

Hereby, we declare under our sole responsibility that **EU-C-2N** manufactured by TECH STEROWNIKI, head-quartered in Wieprz Biała Droga 31, 34-122 Wieprz, is compliant with Directive 2014/53/EU of the European parliament and of the Council of 16 April 2014 on the harmonisation of the laws of the Member States relating to the making available on the market of radio equipment, Directive 2009/125/EC establishing a framework for the setting of ecodesign requirements for energy-related products as well as the regulation by the MINISTRY OF ENTREPRENEURSHIP AND TECHNOLOGY of 24 June 2019 amending the regulation concerning the essential requirements as regards the restriction of the use of certain hazardous substances in electrical and electronic equipment, implementing provisions of Directive (EU) 2017/2102 of the European Parliament and of the Council of 15 November 2017 amending Directive 2011/65/EU on the restriction of the use of certain hazardous substances in electrical and electronic equipment (OJ L 305, 21.11.2017, p. 8).

For compliance assessment, harmonized standards were used:
 PN-EN IEC 60730-2-9 :2019-06 art. 3.1a Safety of use
 PN-EN 62479:2011 art. 3.1 a Safety of use
 ETSI EN 301 489-1 V2.2.3 (2019-11) art.3.1b Electromagnetic compatibility
 ETSI EN 301 489-3 V2.1.1:2019-03 art.3.1 b Electromagnetic compatibility
 ETSI EN 300 220-2 V3.2.1 (2018-06) art.3.2 Effective and coherent use of radio spectrum
 ETSI EN 300 220-1 V3.1.1 (2017-02) art.3.2 Effective and coherent use of radio spectrum

Wieprz, 20.11.2020

Paweł Jura *Janusz Master*
 Paweł Jura Janusz Master
 Prezesi firmy